

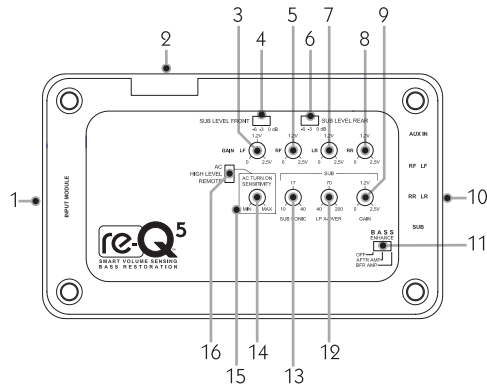

VOLUME SENSING BASS RESTORATION DEVICE™

re-Q⁵, the 5-channel volume sensing bass restoration device, is designed to restore bass when adding aftermarket amplifiers to a factory audio system. Most OEM systems “roll off” the bass to avoid damaging the speakers at higher volume levels. While this is acceptable when using stock speakers, it’s not desired when adding amplifiers as it limits the low frequency output of your system. Some try to fix this problem by maxing out the gains of an amplifier for added bass response at higher volumes, but when the volume is turned down, there is too much bass for the midrange and highs.

re-Q⁵ solves these problems by sensing the input from the head unit to add more bass at high volume levels, and balances the bass response at lower volume levels. You get the bass you want with added performance while keeping your factory radio and your steering wheel controls.



re-Q⁵ Features

- | | | |
|----------------------------|---------------------------|---------------------------------|
| 1. Input Module Connector | 7. Left Rear Gain | 13. Sub Sonic Crossover |
| 2. Power Output Indicator | 8. Right Rear Gain | 14. AC Turn on Sensitivity |
| 3. Left Front Gain | 9. Sub Gain | 15. AC Signal Present Indicator |
| 4. Front Sub Level Control | 10. Low RCA Level Outputs | 16. Input Select Switch |
| 5. Right Front Gain | 11. Bass Enhance Switch | |
| 6. Rear Sub Level Control | 12. LP Crossover | |

Input Module Wiring

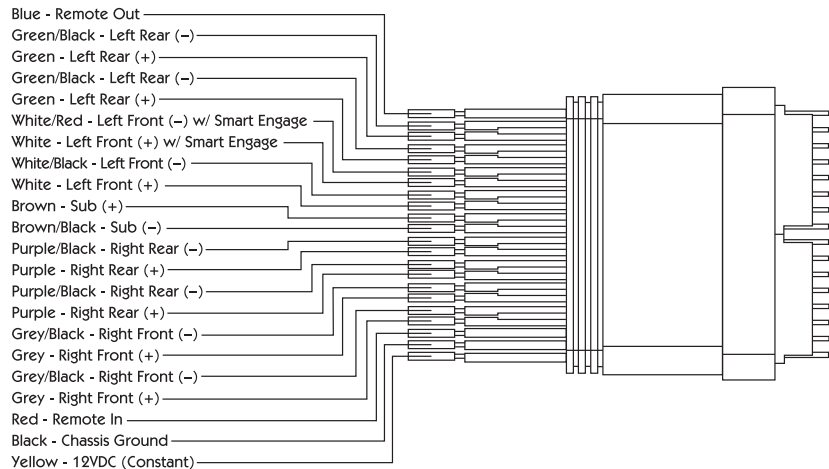

Installation

re-Q recommends that you have your device installed by an authorized re-Q dealer, preferably MECP certified.

1. Disconnect the negative battery terminal from your vehicle’s battery.
2. Tap into the factory speaker and subwoofer (if applicable) wires. Connect signal in onto the re-Q⁵ harness. (Fig. 1)
NOTE: Phase is extremely important when summing! If reversed you will cause a cancellation in your system.
 - a. After connecting the factory speaker leads to the input of the re-Q⁵, disconnect all speakers that will be powered by the aftermarket amplifier(s).

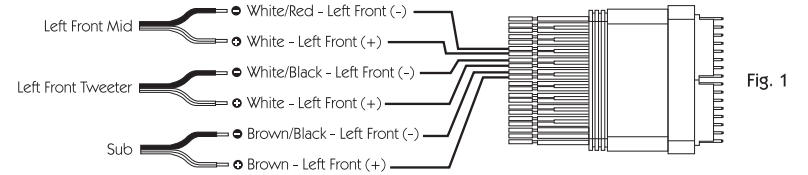

Fig. 1

NOTE: When using the summing feature of the re-Q⁵, be sure to connect the midrange and tweeter to the same colored pairs of wires. For example, use one grey and grey with black stripe for the front right tweeter and the other grey and grey with black stripe for the front right midrange.

NOTE: When not using midrange and tweeter summing, use the white speaker wire pair with the red stripe for front left channel input.

NOTE: For best performance disconnect the factory sub when adding aftermarket amps and subs.

- b. If an entire channel of the speaker inputs is not being used, twist the positive and negative wires of that input together and insulate the connection. This is not necessary for the unused summing inputs, only if the entire LF, RF, RR, LR, or Sub input channels are not used at all.
3. The re-Q⁵ features three turn on settings for maximum installation flexibility. Deciding on which remote setting to use depends on which type of signal is created by your head unit, and whether your factory audio system creates any audible noise or pops when turning on or off. The three settings are as follows:

- a. Remote Mode - Attach red wire to a switched 12V source that is on when the car’s head unit is on. Set the Input Select switch to the Remote position, and the re-Q⁵ will turn on/off only when voltage is applied/removed from this wire.
- b. High Level Mode using Smart Engage™ - Requires that DC voltage be present on the speaker input wires to allow the re-Q⁵ to turn on and off. Not all vehicles have DC voltage on the speaker wires. To test for DC voltage, attach the (+) end of a volt meter to one speaker lead and the (-) to chassis ground of the vehicle. If there is 6V or more of DC voltage at the speaker lead when the head unit is on, the re-Q⁵ will be able to sense the signal from the head unit and turn on. Set the Input Select Switch to High Level and the re-Q⁵ will turn on/off with the head unit.
- c. AC Mode using Smart Engage™ - This setting is intended for vehicles that do not have DC voltage on the speaker leads. This setting requires adjusting the sensitivity of the re-Q⁵ to turn on when music signal is present on the speaker input wires. Set the Input Select Switch to AC and the re-Q⁵ should turn on with signal from the head unit. The re-Q⁵ is shipped with the sensitivity set to the maximum level. To ensure the sensitivity is not set too high for the application, confirm the re-Q⁵ turns off with the head unit. Note there is approximately a 15 second delay for the re-Q⁵ to turn off after the head unit is turned off. The delay is to prevent the unit from shutting off when there are pauses in the music or when changing tracks or CDs. If the re-Q⁵ does not turn off after 15 seconds, adjust the Turn On Sensitivity knob counter-clockwise in small increments until the re-Q⁵ turns off after the 15 second delay. (Fig.2)

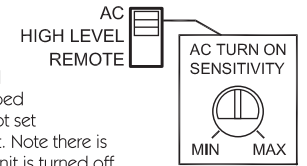

Fig. 2

NOTE: When using High Level (DC) or AC signal sensing, the white input wire pair with the red stripe must be used to accurately sense the voltage from the head unit.

NOTE: All three turn on settings will trigger the blue 12V remote output wire on the re-Q⁵ harness.

4. Using the provided fuse, connect the Yellow (12VDC Constant) power wire from the re-Q⁵ to the power source by tapping off your amplifier’s power wire or by running a separate wire directly to a fused constant 12V source.
5. Connect the black (Chassis Ground) wire from the re-Q⁵ to the chassis of the vehicle. Remove the paint at the ground location to connect directly to the bare metal of the chassis. When the re-Q⁵ is grounded at the same location as the amplifier, it functions as a ground loop isolator (Fig. 3).

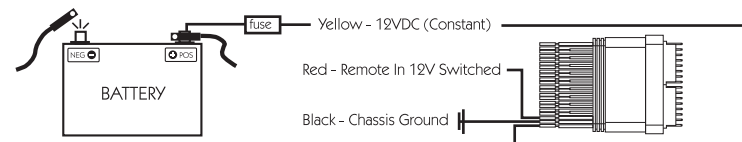

Fig. 3

